

Material: SUJ2  
HRC: 55-60

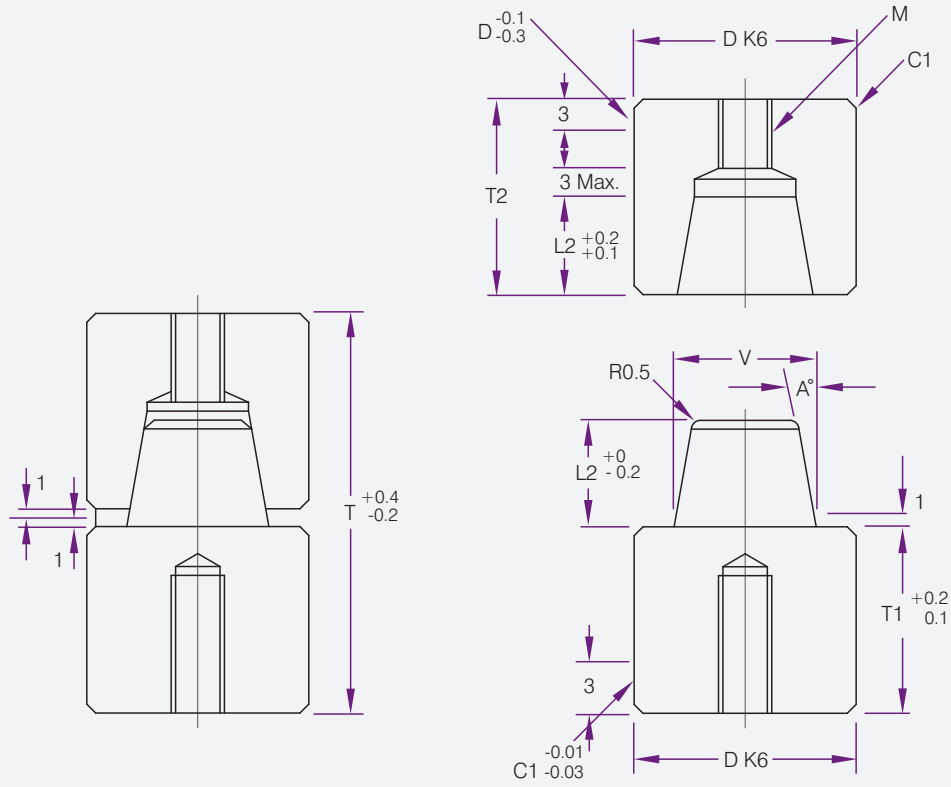

D k6	Tolerance
16	+0.012 +0.001
20	+0.015 +0.002
25	
30	
32	+0.018 +0.002

Product Code	T	T1 . T2	MxL	A	V	L1	L2
TPL16	30	14	M5x10	5°	10	5	6
TPL20	40	19	M6x12	5°	13	8	9
TPL25	50	24	M8x16	5°	16	11	12
TPL30	60	29	M10x20	5°	20	14	15
TPL32	60	29	M10x20	5°	20	14	15