

Progressive's CounterView positively monitors mold activity, validates process monitoring data, and assists mold maintenance procedures.

- Maximum operating temperature is 120°C (250°F)
- Counter: Bib-resettable mechanical, 7 digit.

Parting Line Mount

- Makes unit easily visible to operator

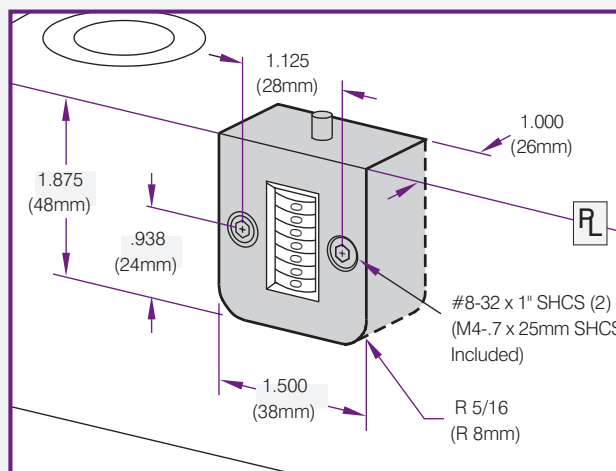

Product Code	Description
CVPL-100	Inch Standard
CVPL-200	Metric Standard

Internal Extension Mount

- Machinable 200mm (8") extension allows installation to sup. plate or rail.

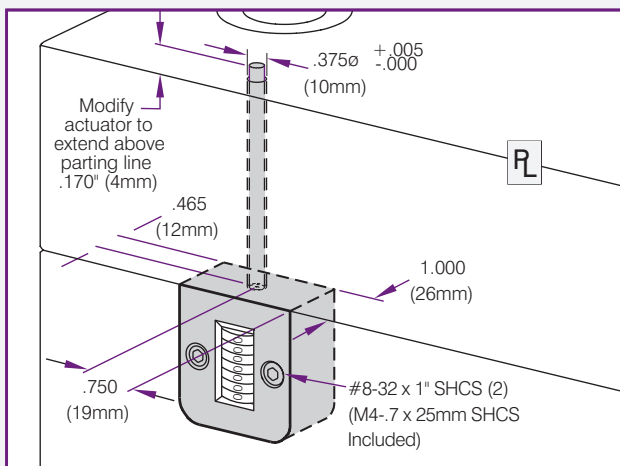

Product Code	Description
CVIN-100	Inch Standard
CVIN-200	Metric Standard

External Mount

- No pocket machining necessary. Designed specifically for retrofit applications

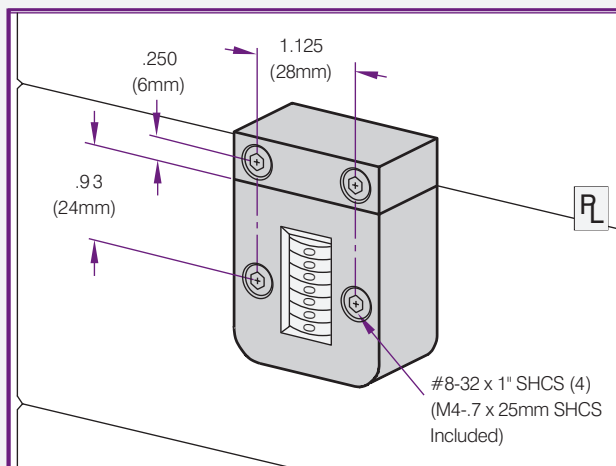

Product Code	Description
CVEX-100	Inch Standard
CVEX-200	Metric Standard