

Maximum Injection Pressure: 2.500 Kgs/cm²

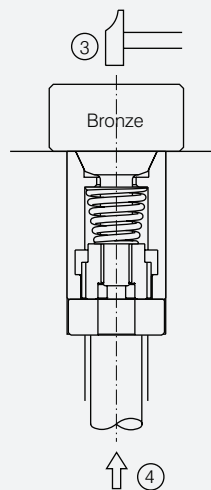

Maximum machining allowed

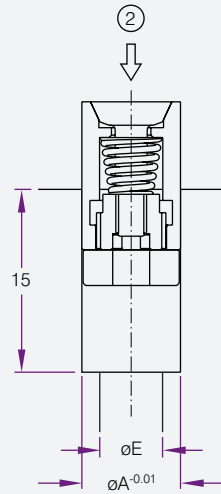
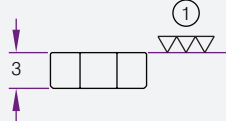
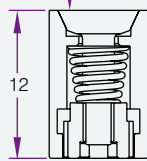
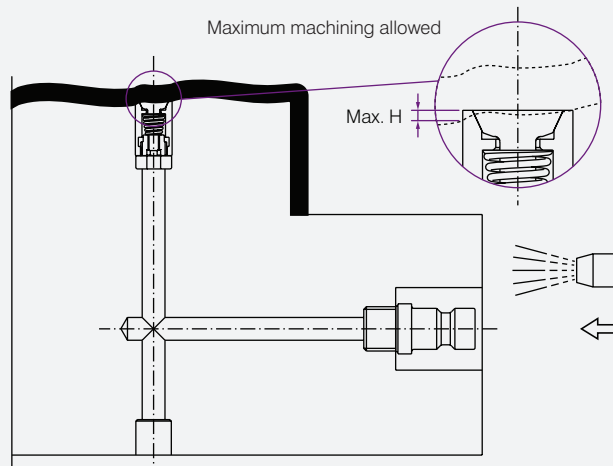

Material: INOX. 1.4034
 Hardness: 51 ± 3 HRC.
 Working pressure: 2-10 BARS.

Product Code	A	B	D	E	F	H
VH.086515	8	6.6	2	5	7.8	0.75
VH.121015	12	9.9	2.9	5	11.8	1