

K = Force to release the RC

Slide Retainers

Mat.: 1.8159

Hardened: 45 ± 3HRC

Patented System

Less machining for installation compared to similar products on the market.

Minimum space required for installation. Reduces costs in tool downtime.

Offers a standard solution to the moulder.

Product Code	A	B	C	E	F	G	H	K	R	T
RC.123006	12	30	6x20	21	5	4	16	5 Kg	6	M5x16
RC.164008	16	40	8x20	28	6	5	15	7 Kg	8	M6x25
RC.205010	20	50	10x24	34	8	6	17	14 Kg	10	M8x30
RC.246012	24	60	12x32	42	10	7	23	21 Kg	12	M10x40
RC.328012	32	80	16x40	56	12	9	27	28 Kg	16	M12x50
RC.328016	32	80	16x40	56	16	9	25	38 Kg	16	M12x50



Optional Dowel Pins

Mat.: 1.3505

Hardened: 60 ± 2HRC

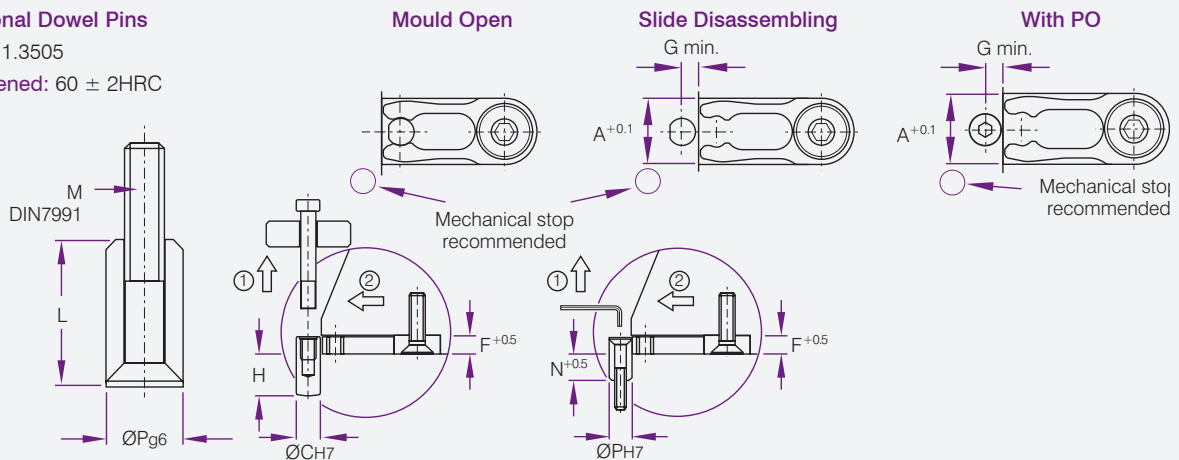

Product Code	L	M	N	P
PO.120320	12	M3x20	7.5	6
PO.150425	15	M4x25	10	8
PO.200530	20	M5x30	13	10
PO.250635	25	M6x35	16	12
PO.340850	34	M8x50	23	16