

Mould closed

With the mould closed, air is trapped inside the cavity. If injection starts, the air will be cornered, heated and compressed by the plastic, producing poor quality plastic parts. We have to create a Vacuum!

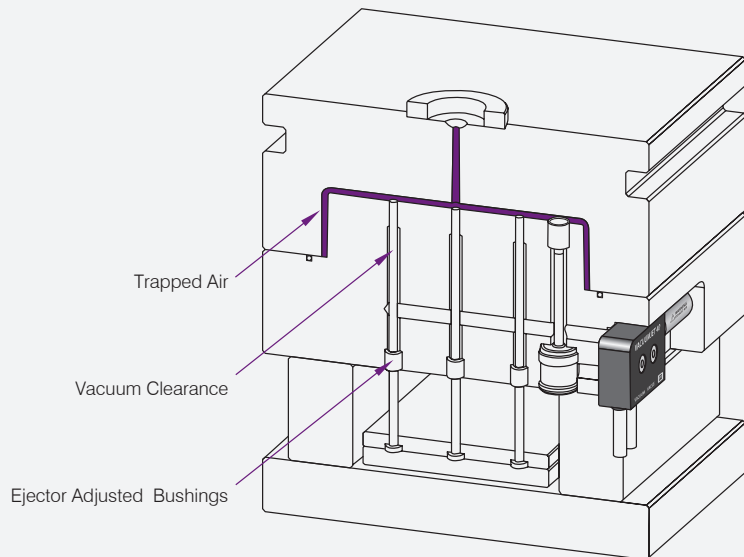

Creating vacuum in the cavity

To optimize the injection process we have to take out the air from the cavity. There are several methods to accomplish this, but in all of them it is the injected plastic that pushes out the air. With VACUUMJET, when it is activated prior to the injection, a valve is opened and vacuums the air, therefore, leaving the cavity prepared for the injection.

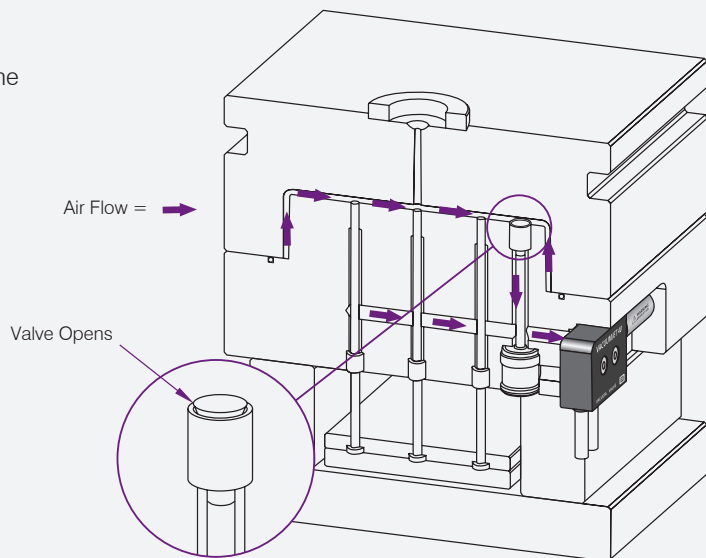

Injection starts

The Vacuumjet continues sucking the air during all the injection process, to guarantee the maximum ease of the plastics fluidity, therefore reducing the pressure needed.

Ejection process

When the injection is finished, the Vacuumjet stops, and as with all the moulds, the plastic is cooled and the part is ejected...but with the Vacuumjet system, we obtain greater quality plastic part, with at least the same injection, if not faster, and without altering the optimal injection parameters.

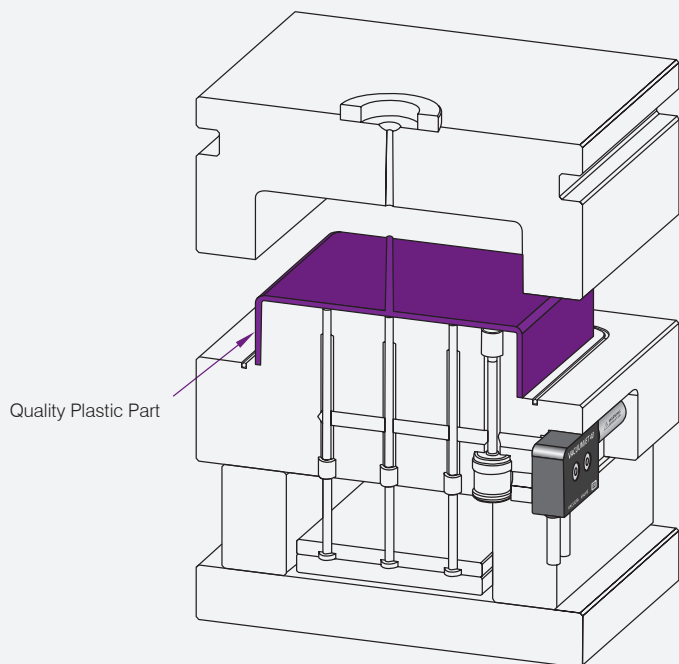



Material: Aluminium
 Maximum working temperature: 80°C
 Patented System

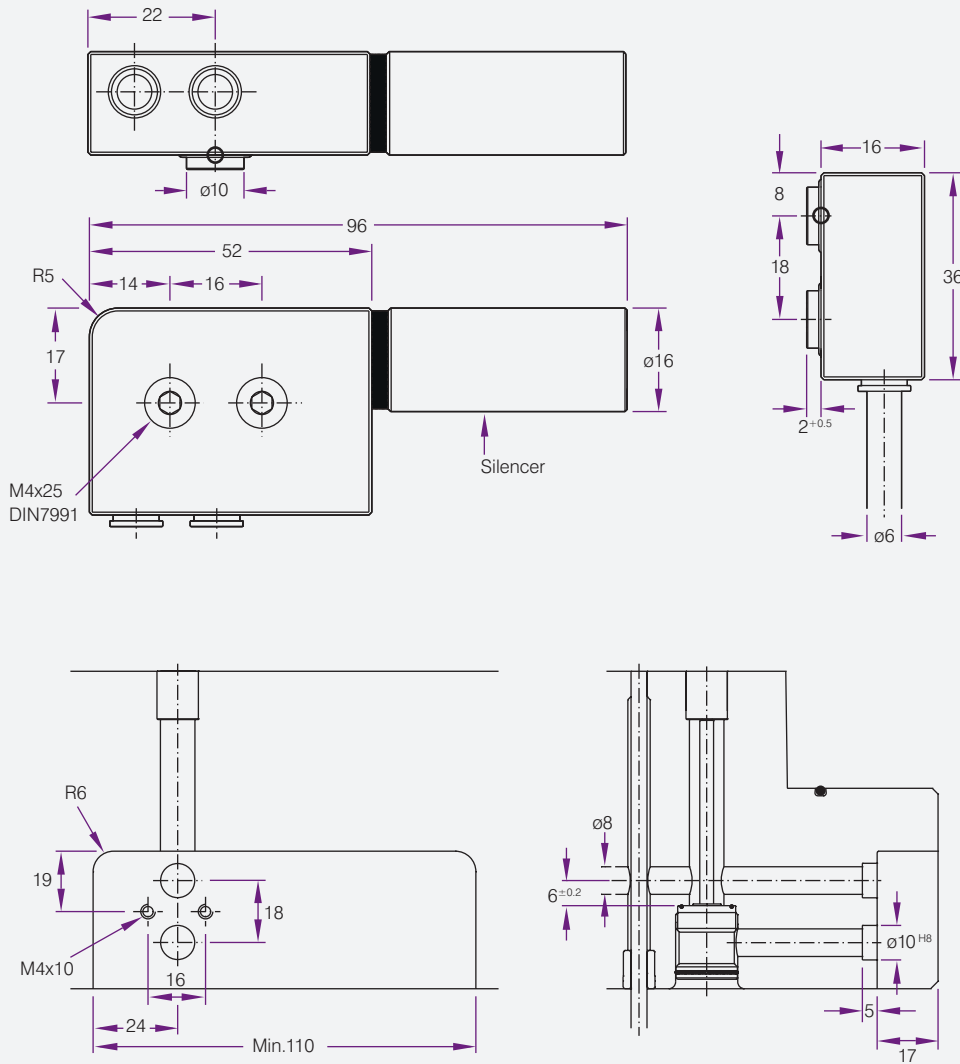

Product Code	Description	Supply Pressure	Max. Vacuum	Max. Flow	Consumption	Recom. W
VJ.600000	Vacuumjet 60L	5-6 Bar	-900 mbar	75nl./Min.	60nl./Min.	W.161416



Material: Aluminium
 Max. working temperature: 80°C
 Patented System

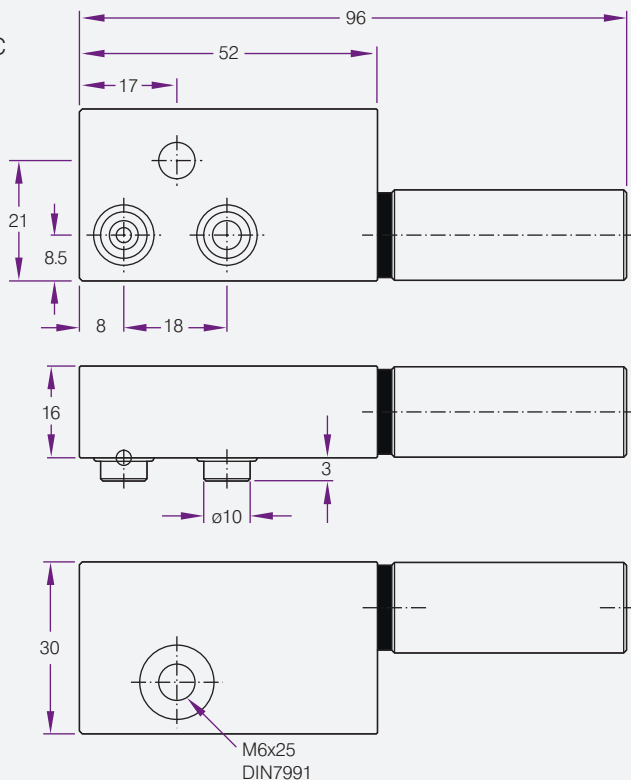

Several units can be connected together in the same vacuum circuit.

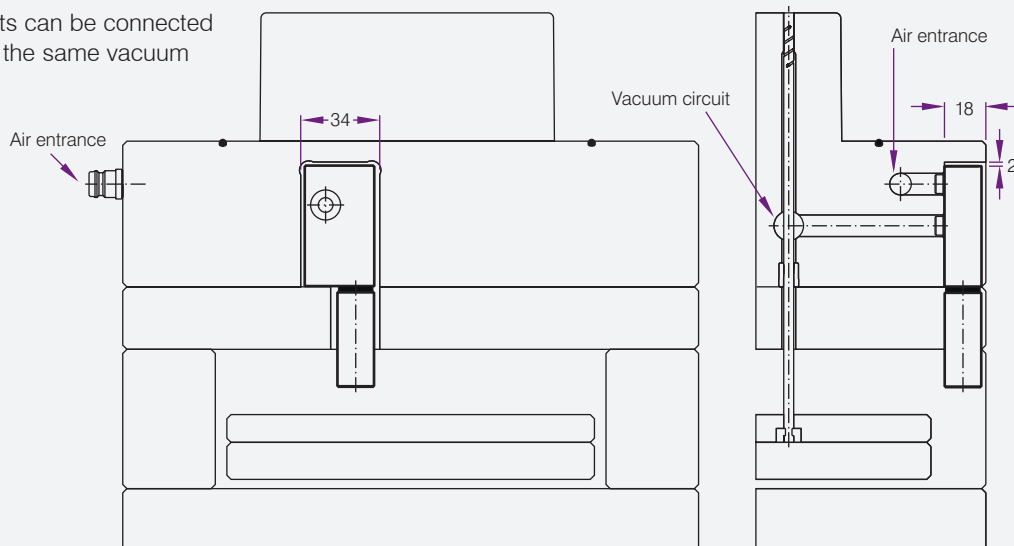

Product Code	Type
VG523016	60L