



Manifold systems to suit all your moulding requirements

Mastip's experienced teams can design and manufacture manifold systems to suit all your moulding requirements. All Mastip manifolds are designed to deliver a uniform melt to each nozzle, ensuring cavity-to-cavity consistency. This is achieved through natural balancing of the flow channels and ensuring constant temperature profiles are maintained across the manifold block. Small cavity or high cavity systems, simple single level or complex multi-level stack systems, thermal gate or valve gate systems, Mastip can provide you with a Manifold system to meet your requirements in standard high quality mould base steel or stainless steel plates.

Scan this QR code to go to website for further information:



Standard Layouts, Exceptional Results

Mastip has an extensive range of standard or customized manifold designs that ensure cavity-to-cavity consistency through the normal or theological balancing of flow channels.

Each manifold incorporates durable, high quality components that deliver fast cycle times, precise gate control and superior quality parts.

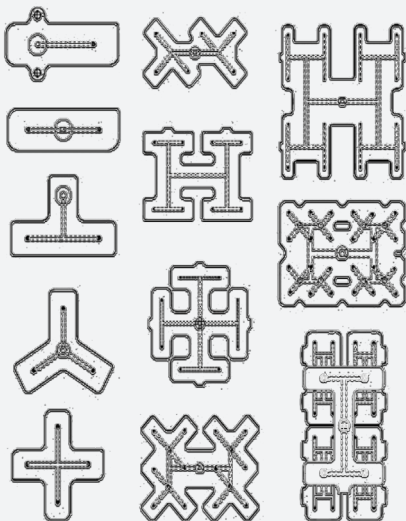

Durable, Long-lasting Components

All manifolds are equipped with superior components including pressed-in heaters, ceramic connectors and high quality mould base or stainless steel plates, enabling them to perform under the most demanding applications and conditions.

Mastip's manifold range is further complimented by the industry leading X-Range nozzles and the extensive range of tip and nut combinations to deliver high performing, durable solutions able to meet the demands of the most abrasive and difficult to mould resins.

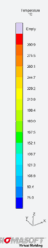
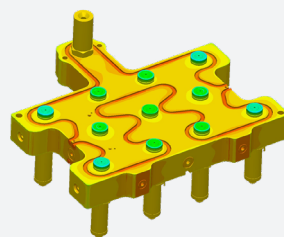

Designed, Manufactured and Tested

Every manifold goes through extensive design and analysis to ensure the following:

- optimised melt delivery
- improved production efficiencies
- perfect cavity-to-cavity filling
- excellent gate quality

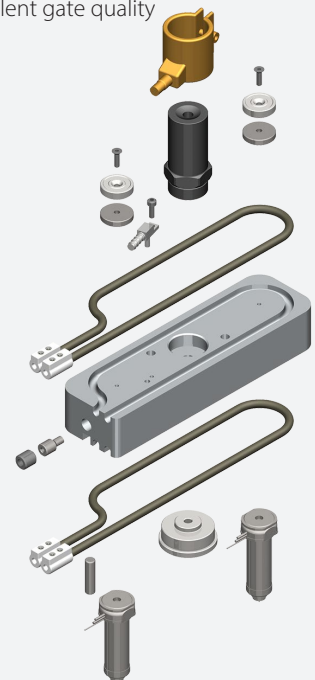

mastip™
hot runner solutions

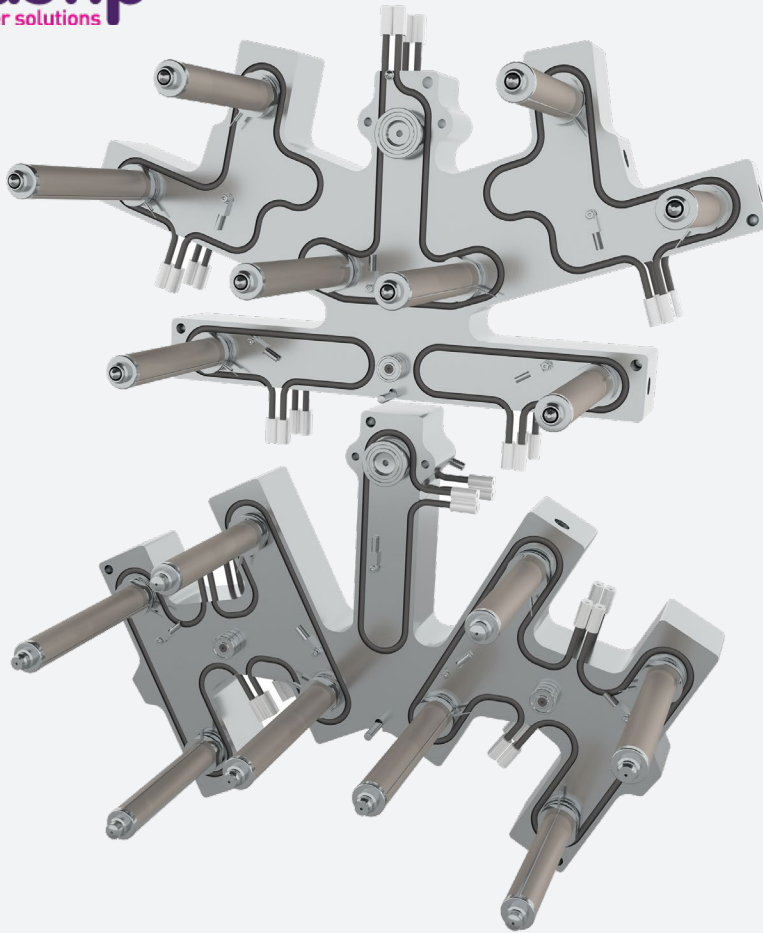

Unique Designs for Multi-Component Moulding

Multi-material moulding is a common way to create parts with two or more types of material in order to provide stability, functionality or aesthetic appeal over traditional single type material parts. Common examples of this include razor and toothbrush handle grips.

Often referred to as multi-shot, co-injection or over-moulding, multi-material solutions are typically uniquely designed systems providing an effective and cost-efficient way to produce custom parts requiring multiple types of material or colours in a single mould.

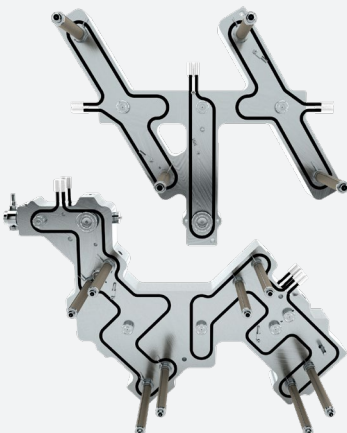

Designed, Tested and Supported

Mastip works closely with our customers to design customised solutions that solve their unique requirements for multi-material moulding.

Each system is supplied with installation and mould recommendations and backed by our global service and support network.

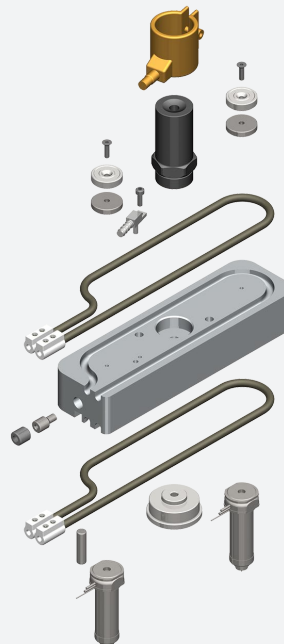

From Simple to Technically Advanced Multi-Material Systems

Mastip has extensive experience in supplying solutions for multi-material and multi-colour applications. Whether it is over moulding soft grips or different colours on single part, Mastip has the technology and technical expertise to develop the right multi-material hot runner solution for your needs. From simple high cavity plastic packaging to technically advanced components such as structural and engineering parts for the automotive industry, incorporating Mastip's multi-material systems into your mould can simplify your production, deliver quality parts and save you time and money on your product assembly.

Scan this QR code to go to website for further information.

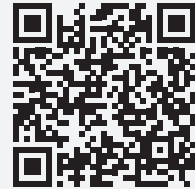

Durable, Long-lasting Components

All manifolds are equipped with superior components including pressed-in heaters, ceramic connectors and high quality mould base or stainless steel plates, enabling them to perform under the most demanding applications and conditions.

Mastip's manifold range is further complimented by the industry leading X-Range nozzles and the extensive range of tip and nut combinations to deliver high performing, durable solutions able to meet the demands of the most abrasive and difficult to mould resins.



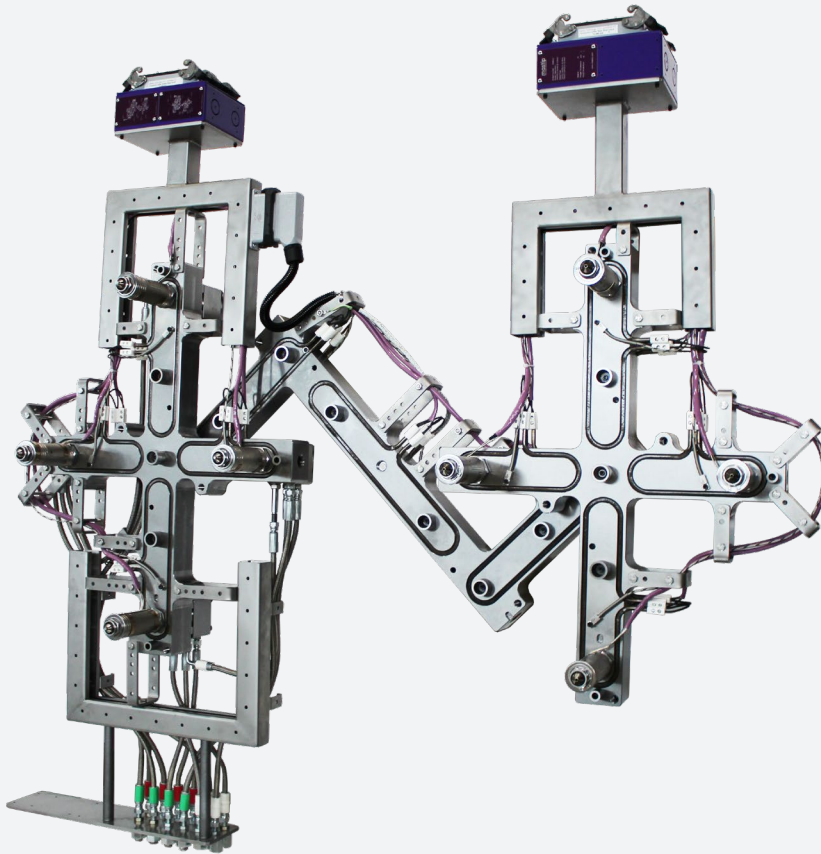

Ready ▶ Set ▶ Inject

Following on from the ground breaking success of Mastip's Nexus Thermal Gate we are proud to introduce the **Nexus Valve Gate with Cylix actuation.**

Mastip's next generation Nexus™ Systems are delivered Pre-Assembled and Pre-Wired as a complete turn-key solution for quick and simple installation.

Both the Nexus Thermal Gate and the Nexus Valve Gate Systems incorporate the advanced leak protection of FlowLoc™ Technology.

Scan this QR code to go to website for further information

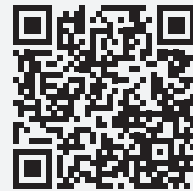

Nexus™ systems are designed for fast, simple installation out of the box without requiring any further assembly

Nexus™ systems feature fully customisable frames, electrical connections, tip and nut options and nozzle lengths to suit your application requirements.

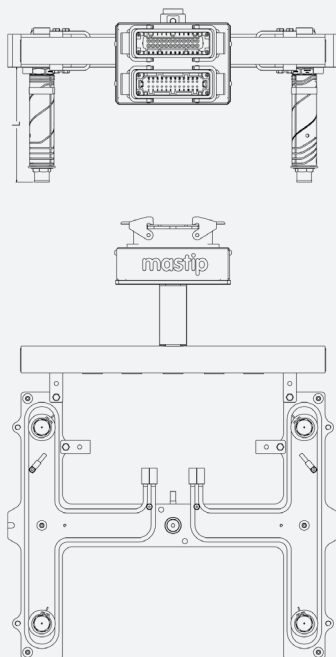

Cylix™ Valve Gate Actuation

The Cylix™ Cylinder features Pneumatic Valve actuation in a thermally stabilized system mounted directly to the manifold. With the ability to adjust valve pin height and incorporating long life seals and bearings, it is the optimal solution for precise control of your moulding requirements.

Nexus™ System with FlowLoc™ Nozzle

The FlowLoc nozzle range features a threaded base that attaches to the manifold providing a secure, leak-proof operation. With advanced heating technology, the FlowLoc delivers superior thermal performance for a wide moulding window

**All measurements are in millimetres.
* Further nozzle lengths are available on request**

