

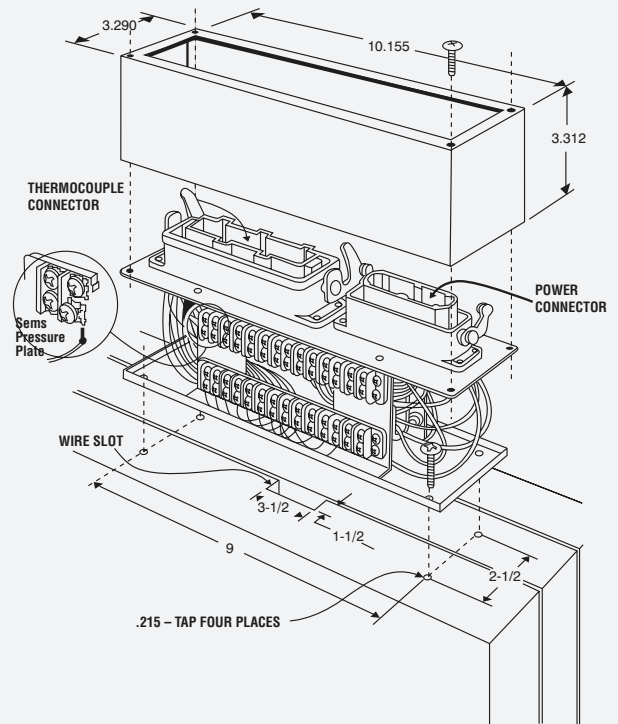

1. The terminal blocks are completely prewired to both the Power and Thermocouple Connectors.
2. Terminal blocks are numbered by MOLD ZONE for ease of installation and troubleshooting.
3. Feed the wires from the mold wire slot through the opening(s) in the bottom of the Mold Wiring System. Slide the mold wires under the SEMS pressure plate on the appropriate zone-numbered terminal.
4. The RED and WHITE wires are the THERMOCOUPLE SIDE. Install thermocouple wire from the mold. + (White/ upper) - (Red/lower) to the corresponding zone number on the upper and lower terminal blocks.
5. Install the POWER wires on the opposite two terminal blocks marked Power side to corresponding number on the terminal blocks, one to upper and one to lower.
6. Place the cover over the Mold Wiring System and tighten with the four screws supplied.



Product Code	Zones	Length Y	Width X	Height H	Mounting Hole M1	Mounting Hole M2
PTBC005-A	005	8.66"	2.75"	4.50"	1.500	8.031
PTBC008-A	008	9.47"	2.75"	4.50"	1.500	8.843
PTBC012-A	012	10.53"	2.75"	4.50"	1.500	9.906



Product Code	Amps
ABC10	10
ABC15	15