

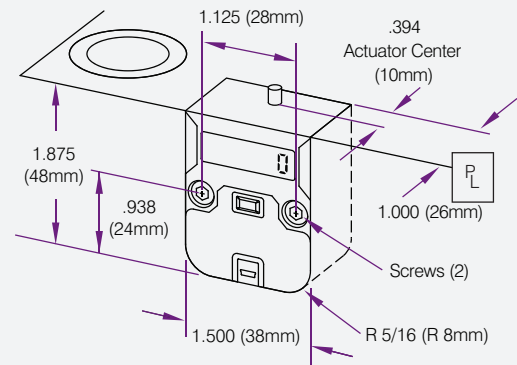

- 7-digit LCD display with a push button to move through the display modes
- 4GB Flash drive for file storage and 4+ year battery within monitor
- Water resistant with an ingress protection rating of IP52
- Maximum temperature: 190° F (90° C)
- Dimensional compatibility with Progressive's mechanical CounterViews
- Mini USB connectivity for data retrieval with cables sold separately



507288 Cycle Count
Total cycles for the life of the mould is presented on the main screen of the CVE Monitor

EFF 93 Efficiency Percentage
The percentage of time that the mould has been actively cycling vs being idle

CYE 8.7 Cycle Time
Since the first production cycle, the cycle time is shown in seconds for the life of the mould.

EFFr 96 Efficiency Percentage-Recent
The percentage of time the mould has been active in the past 25,000 cycles.

CYEr 9.6 Cycle Time-Recent
Cycle time for the past 25,000 cycles

RES 1259 Cycle Count Rest
A separate counter that can be reset to 0 for interim monitoring of cycles when pressed and held

FLASHdr Embedded Flash Drive
Users can utilize the 4GB flash drive on the CVE Monitor by connecting the device to a PC using an industry-standard mini USB cable, sold on the next page. Users press the button to get to the flash drive mode and then the storage area is represented on the PC by a new drive letter

Product Code	Description
CVE	CVe Monitor v2 mould Maker/moulder version including #8-32 x 1" SHCS (2) and M4 x 25mm SHCS (2)
CVE-INT	Internal Extension Rod (8"/200mm) including a hex key for CVE Monitor set screw removal.
CVE-EXT	External Mounting Block including #8-32 x 1" SHCS (2) and M4 x 25mm SHCS (2)